

LEVER CLAMP CYLINDERS

without/with position control, double-acting, pmax. 350 bar

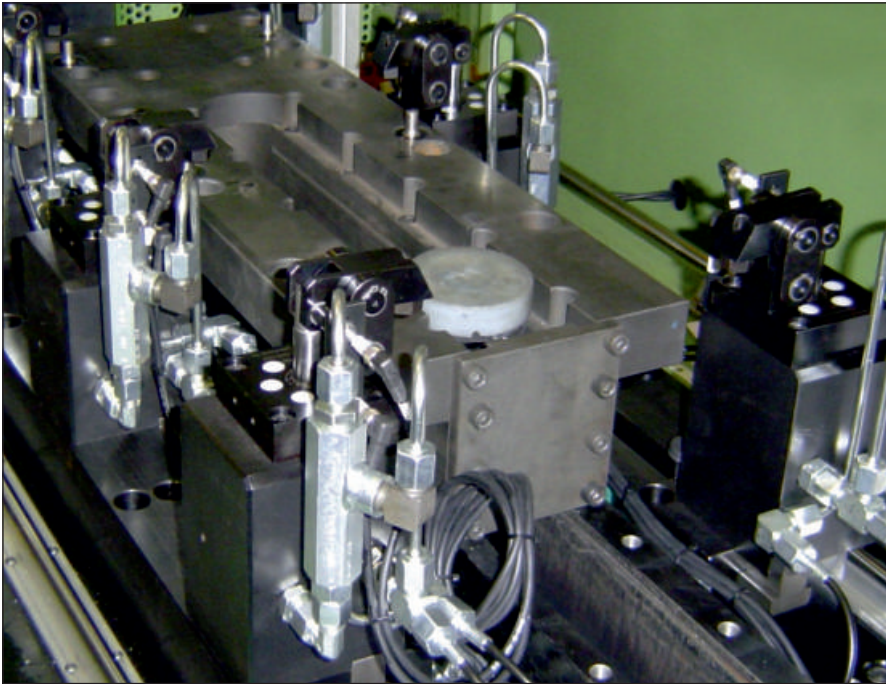

Application example break test bench:

Various workpieces are clamped by various adapters. Test specimens are changed every five minutes. Six lever clamp cylinders operate with two clamping circuits. Additional protection is provided by piloted check valves. Originally, the workpieces were fastened with screws. It used to take one minute to change a workpiece. With the lever clamp cylinders from HYDROKOMP it takes only five seconds to change one workpiece.

Description:

Lever clamp cylinders are primary meant for individual cases, where the clamping position needs to be free for handling when the workpiece is unclamped.

Compared to swing clamp cylinders, lever clamp cylinders have a more compact design and higher clamping load.

Lever clamp cylinders are especially meant for those cases, where bothering contours make the use of swing clamp cylinders unsuitable.

Through a piston the high force density is induced into the clamp lever.

Since the clamp lever has a movable position, the clamping point can be fully released. Besides the standard clamp lever also special clamp levers can be mounted. The resulting clamping load can be determined through the chart on page 6.

Operating conditions:

The lever clamp cylinder is only double-acting, hydraulic. Therefore, clear clamping times and unclamping times are given.

For hydraulic oil supply G1/8 resp. G1/4 threaded port or manifold connection with O-ring can be used optional.

In horizontal position the clamp lever provides its optimal clamping load. Workpiece tolerances with a position deviation of appr. +/-8.5° can be compensated easily.

Position control (optional):

The lever clamp cylinder can be equipped with full-length piston rod. The survey can be made through inductive or pneumatic proximity switch.

On our website www.hydrokomp.de you can download 2D and 3D files of our lever clamp cylinders.

General technical data:

Piston Ø	[mm]	16	25	40
Maximum operating pressure	[bar]	350	350	200
Clamping force at 100 bar	[kN]	1,5	3,9	9,5
Clamping force at max. operating pressure	[kN]	5,2	13,8	19,0



Webcode: 025001

We also design and manufacture special designs

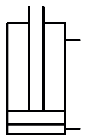

Connections:

- ☒ G1/8 or G1/4 threaded port
- ☒ Manifold connection with O-ring
- ☒ Built-in version

Advantages:

- ☒ Protecting metal wiper
- ☒ Partly retractable housing
- ☒ Oil supply through drilled channels or threaded ports
- ☒ Various installation options
- ☒ Fixture can be easily loaded and unloaded
- ☒ Clamp arms can be optimized on workpiece (see page 6)
- ☒ Inductive or pneumatic position control available (see page 5)



Siemensstraße 16, 35325 Mücke (Germany)
 Phone: +49 6401 225999-0
 Fax: +49 6401 225999-50
 E-mail: info@hydrokomp.de
 Internet: www.hydrokomp.de



Lever clamp cylinders / Threaded port

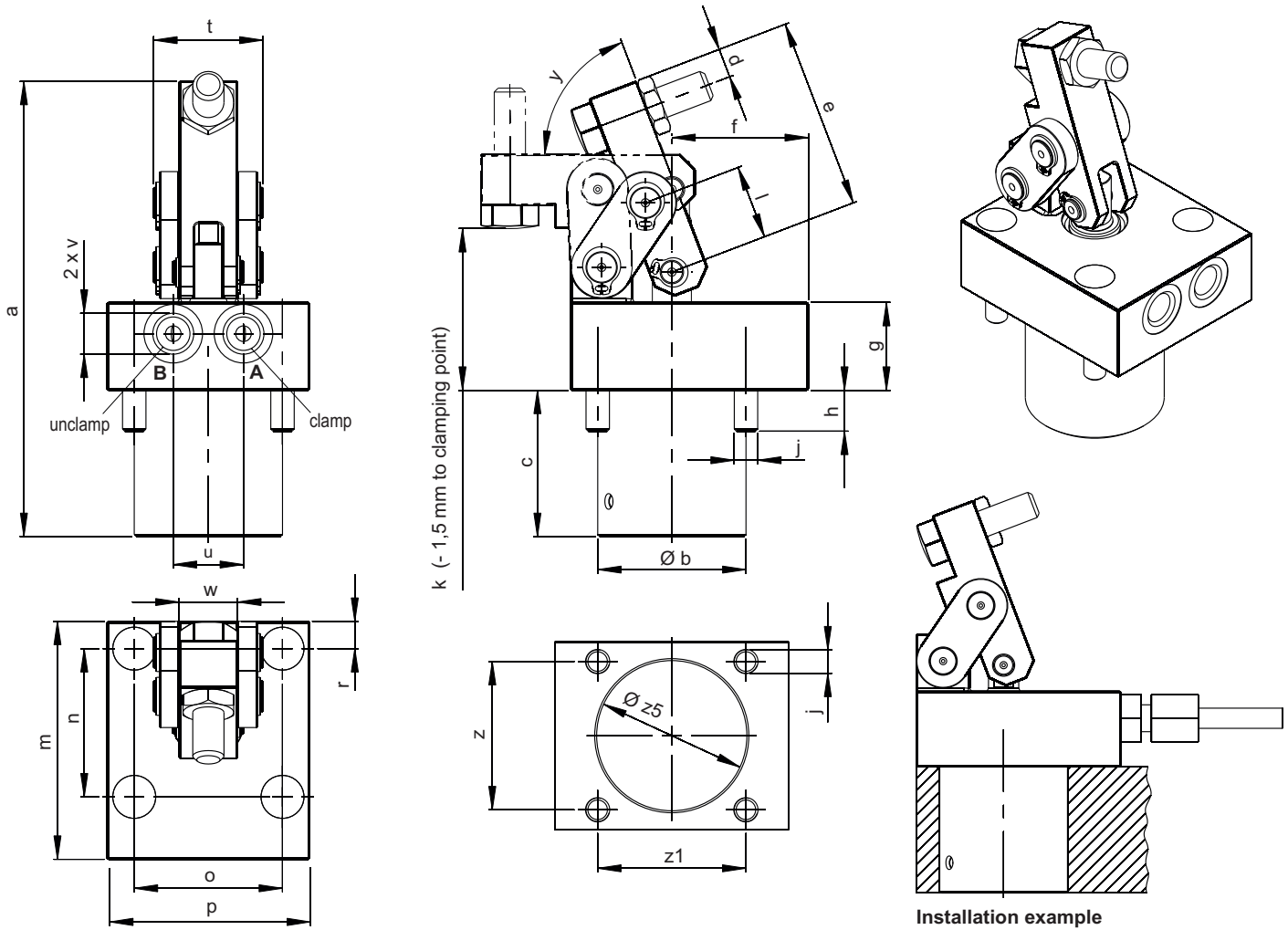

Installation example

Piston Ø	[mm]	16	25	40
Max. operating pressure (p _{max.})	[bar]	350	350	200
Clamping force at 100 bar	[kN]	1,5	3,9	9,5
Clamping force at p _{max.}	[kN]	5,2	13,8	19
a	[mm]	117	156	191
b Ø	[mm]	38	50	70
c	[mm]	37,5	54	67,7
d	[mm]	7,5	10	10
e	[mm]	49	63,5	82,5
f	[mm]	35	44	40,5
g	[mm]	22,5	22	25
h	[mm]	10,5	19	20
j	[mm]	M6, 12 deep	M8, 22 deep	M10, 22 deep
k	[mm]	41,5	50	65
l	[mm]	19	24	31,5
m	[mm]	61	80	85
n	[mm]	38	56	62
o	[mm]	38	56	78
p	[mm]	52	72	100
q	[mm]	-	-	-
r	[mm]	7	8	13,5
s	[mm]	-	-	-
t	[mm]	28	44	66
u	[mm]	18	25	32
v	[mm]	G1/8	G1/4	G1/4
w	[mm]	15	24	36
x	[mm]	-	-	-
y	[degrees]	69	65	65
z	[mm]	38	56	62
z1	[mm]	38	56	78
z2	[mm]	-	-	-
z3	[mm]	-	-	-
z4	[mm]	-	-	-
z5 Ø	[mm]	38,5	50,5	70,5
Order no.		HSZY-016-001	HSZY-025-001	HSZY-040-001

Scope of supply includes:

- 4 pce mounting screws
- 4 pce plastic covers

Spare parts:

☒ Clamp arms (standard)

for piston Ø	Order no.
16 mm	5016-001
25 mm	5024-001
40 mm	5036-001

☒ Contact bolts

for piston Ø	Order no.
16 mm	7013-002
25 mm	7017-001
40 mm	7017-001



Lever clamp cylinders / Manifold connection

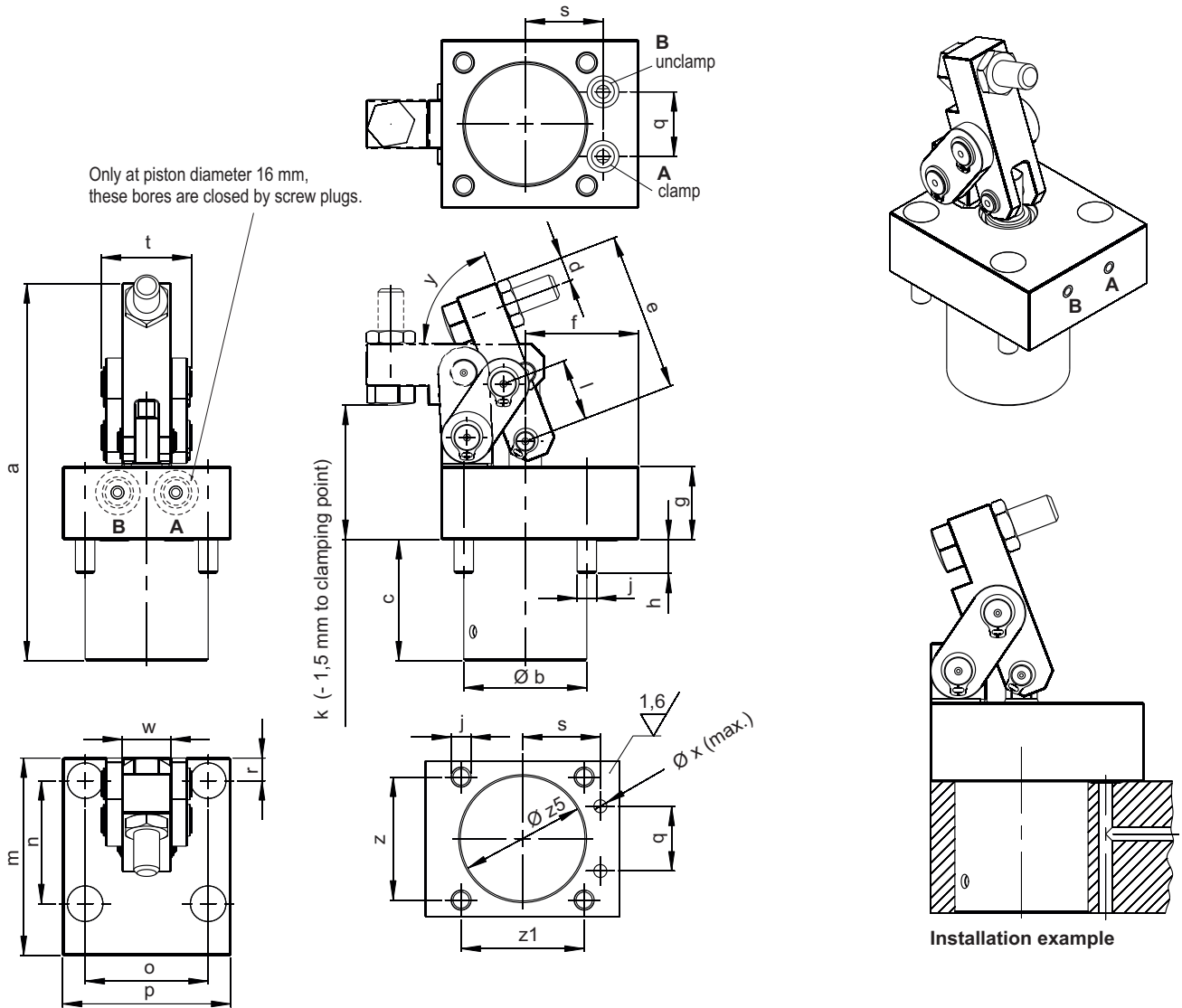

Piston Ø	[mm]	16	25	40
Max. operating pressure (p _{max.})	[bar]	350	350	200
Clamping force at 100 bar	[kN]	1,5	3,9	9,5
Clamping force at p _{max.}	[kN]	5,2	13,8	19
a	[mm]	117	156	request
b Ø	[mm]	38	50	//
c	[mm]	37,5	54	//
d	[mm]	7,5	10	//
e	[mm]	49	63,5	//
f	[mm]	35	36	//
g	[mm]	22,5	22	//
h	[mm]	10,5	19	//
j	[mm]	M6, 12 deep	M8, 22 deep	//
k = optimal clamping point	[mm]	41,5	50	//
l	[mm]	19	24	//
m	[mm]	61	72	//
n	[mm]	38	56	//
o	[mm]	38	56	//
p	[mm]	52	72	//
q	[mm]	20	27	//
r	[mm]	7	8	//
s	[mm]	24	28,1	//
t	[mm]	28	44	//
u	[mm]	-	-	//
v	[mm]	-	-	//
w	[mm]	15	24	//
x Ø	[mm]	4	4	//
y	[degrees]	69	65	//
z	[mm]	38	56	//
z1	[mm]	38	56	//
z2	[mm]	-	-	//
z3	[mm]	-	-	//
z4	[mm]	-	-	//
z5 Ø	[mm]	38,5	50,5	//
Order no.		HSZY-016-002	HSZY-025-002	HSZY-040-002

Scope of supply includes:

4 pce mounting screws
4 pce plastic covers
2 pce O-rings 7x1,5

Spare parts:

☒ Clamp arms (standard)

for piston Ø	Order no.
16 mm	5016-001
25 mm	5024-001
40 mm	5036-001

☒ Contact bolts

for piston Ø	Order no.
16 mm	7013-002
25 mm	7017-001
40 mm	7017-001

☒ O-Rings 7x1,5

for piston Ø	Order no.
16 mm	6010-020
25 mm	6010-020
40 mm	6010-020



Lever clamp cylinders / Built-in version

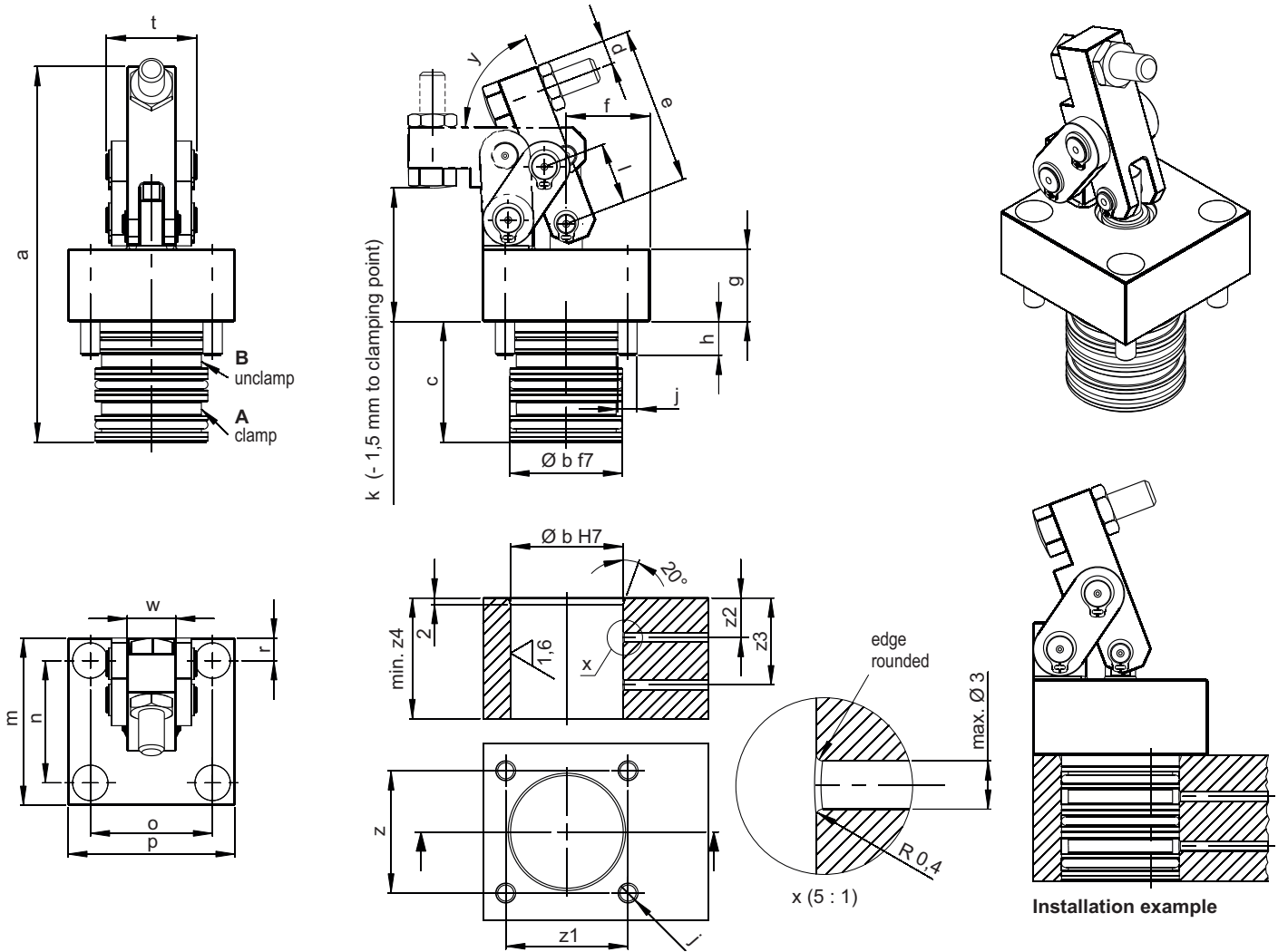

Piston Ø	[mm]	16	25	40
Max. operating pressure (p _{max.})	[bar]	350	350	200
Clamping force at 100 bar	[kN]	1,5	3,9	9,5
Clamping force at p _{max.}	[kN]	5,2	13,8	19
a	[mm]	117	156	request
b Ø	[mm]	35 H7/f7	50 H7/f7	//
c	[mm]	37,5	54	//
d	[mm]	7,5	10	//
e	[mm]	49	63,5	//
f	[mm]	26	36	//
g	[mm]	22,5	22	//
h	[mm]	10,5	19	//
j	[mm]	M6, 12 deep	M8, 22 deep	//
k	[mm]	41,5	50	//
l	[mm]	19	24	//
m	[mm]	52	72	//
n	[mm]	38	56	//
o	[mm]	38	56	//
p	[mm]	52	72	//
q	[mm]	-	-	//
r	[mm]	7	8	//
s	[mm]	-	-	//
t	[mm]	28	44	//
u	[mm]	-	-	//
v	[mm]	-	-	//
w	[mm]	15	24	//
x	[mm]	-	-	//
y	[degrees]	69	65	//
z	[mm]	38	56	//
z1	[mm]	38	56	//
z2	[mm]	12,25	25,2	//
z3	[mm]	27	41,8	//
z4	[mm]	37,5	55	//
z5	[mm]	-	-	//
Order no.		HSZY-016-003	HSZY-025-003	HSZY-040-003

Scope of supply includes:

- 4 pce mounting screws
- 4 pce plastic covers

Spare parts:

☒ Clamp arms (standard)

for piston Ø	Order no.
16 mm	5016-001
25 mm	5024-001
40 mm	5036-001

☒ Contact bolts

for piston Ø	Order no.
16 mm	7013-002
25 mm	7017-001
40 mm	7017-001

☒ Seal kits (outside)

for piston Ø	Order no.
16 mm	DS-HSZY-016-003
25 mm	DS-HSZY-025-003
40 mm	DS-HSZY-040-003

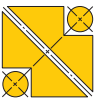

Lever clamp cylinders / Position control

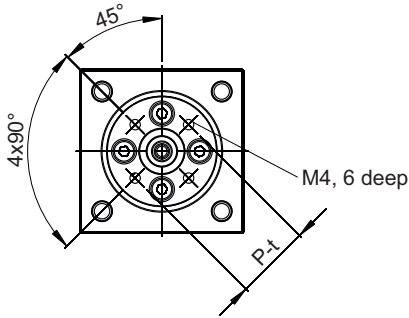

Inductive position control:

Housing 4 x 90°, rotatable

Accessories / Spare parts:

Proximity switch
Plug with cable (length 5 m)

Order no.: 8500-035
Order no.: 8500-036

Pneumatic position control:

Housing 4 x 90°, rotatable

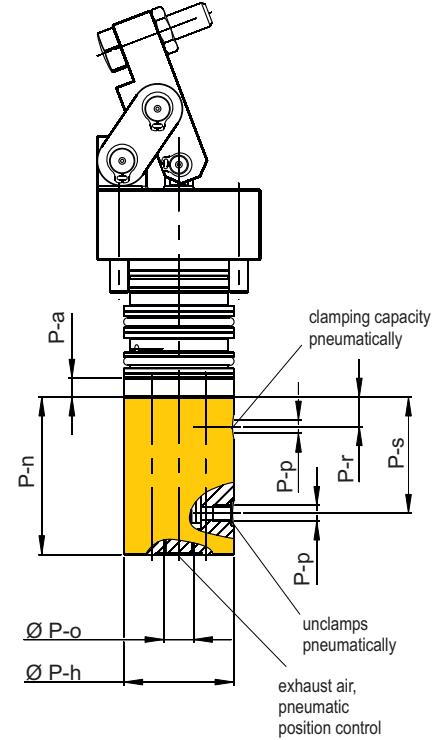
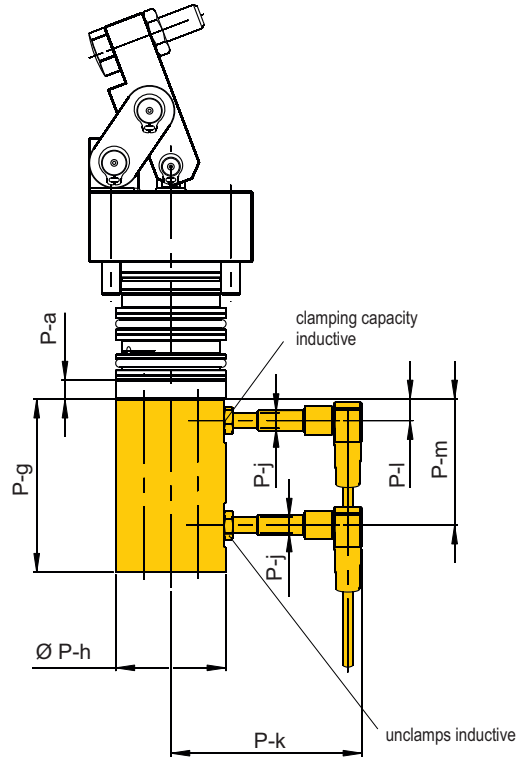
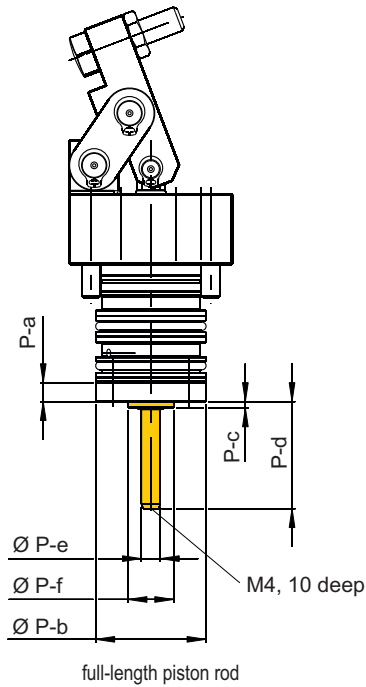

Design	Threaded port			Manifold connection			Built-in cylinder			
	16	25	40	16	25	40	16	25	40	
Piston Ø	[mm]	16	25	40	16	25	40	16	25	40
P-a	[mm]	6	6	request	6	6	request	6	6	request
P-b Ø	[mm]	35	50	//	35	50	//	35	50	//
P-c	[mm]	2	2	//	2	2	//	2	2	//
P-d	[mm]	34	34	//	34	34	//	34	34	//
P-e Ø	[mm]	6	6	//	6	6	//	6	6	//
P-f Ø	[mm]	14,5	14,5	//	14,5	14,5	//	14,5	14,5	//
P-g	[mm]	55	55	//	55	55	//	55	55	//
P-h Ø	[mm]	35	35	//	35	35	//	35	35	//
P-j	[mm]	M5x0,5	M5x0,5	//	M5x0,5	M5x0,5	//	M5x0,5	M5x0,5	//
P-k	[mm]	ca. 60	ca. 60	//	ca. 60	ca. 60	//	ca. 60	ca. 60	//
P-l	[mm]	6,8	6,8	//	6,8	6,8	//	6,8	6,8	//
P-m	[mm]	40	40	//	40	40	//	40	40	//
P-n	[mm]	50	50	//	50	50	//	50	50	//
P-o Ø	[mm]	G1/8	G1/8	//	G1/8	G1/8	//	G1/8	G1/8	//
P-p	[mm]	M5	M5	//	M5	M5	//	M5	M5	//
P-r	[mm]	9,4	9,4	//	9,4	9,4	//	9,4	9,4	//
P-s	[mm]	36,9	36,9	//	36,9	36,9	//	36,9	36,9	//
P-s	[mm]	24	24	//	24	24	//	24	24	//
Order numbers:										
with full-length piston rod	HSZY-...	016-001-P1	025-001-P1	040-001-P1	016-002-P1	025-002-P1	040-002-P1	016-003-P1	025-003-P1	040-003-P1
with inductive position control	HSZY-...	016-001-P2	025-001-P2	040-001-P2	016-002-P2	025-002-P2	040-002-P2	016-003-P2	025-003-P2	040-003-P2
with pneumatic position control	HSZY-...	016-001-P3	025-001-P3	040-001-P3	016-002-P3	025-002-P3	040-002-P3	016-003-P3	025-003-P3	040-003-P3



Lever clamp cylinders / Special clamp arms (customised)

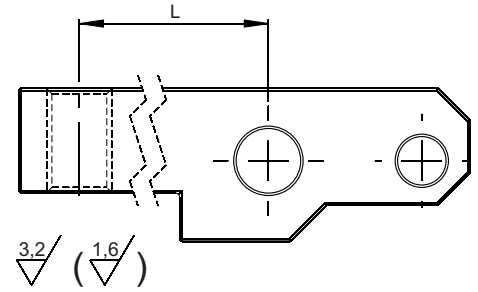
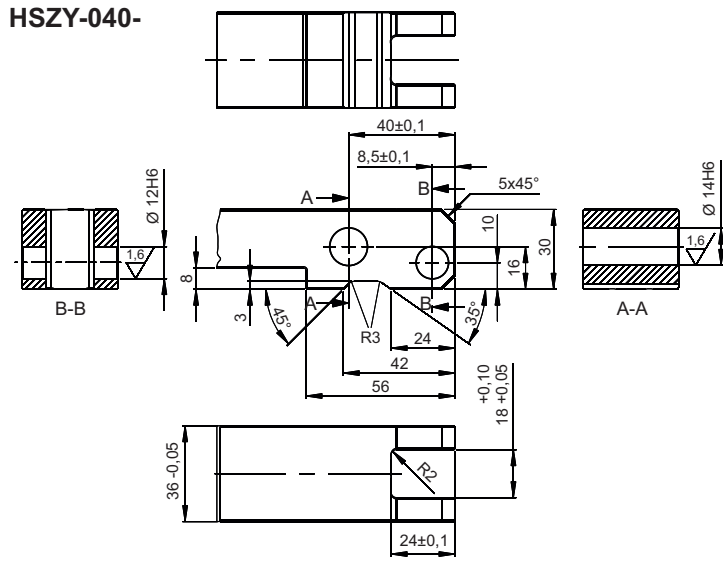
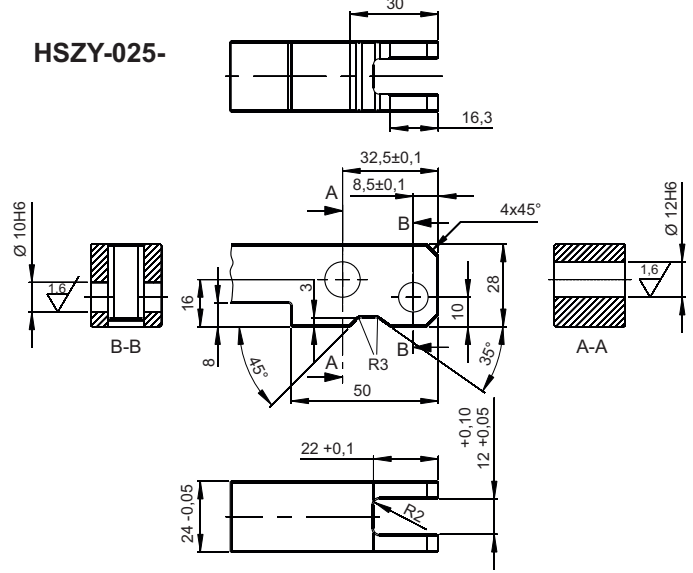
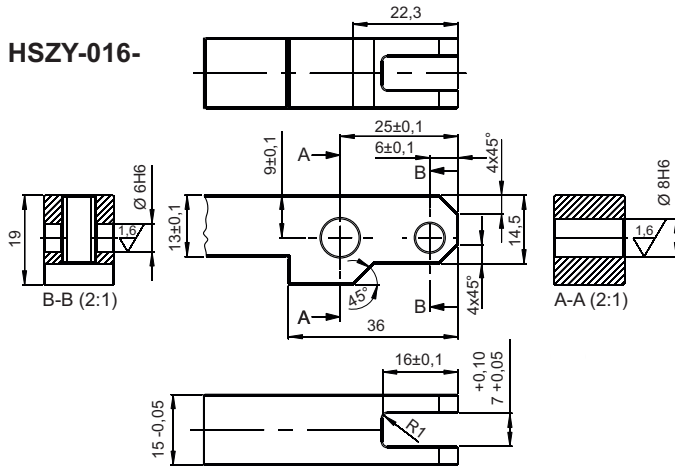

Materials and technical data:

material 42 CrMo 4 browned
tempered to 1.000 N/mm²
all edges 0,3 x 45°
bores 0,2 x 45

Clamping force F depending from clamp arm length L and operating pressure load p:

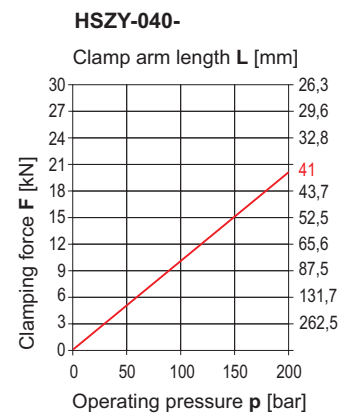
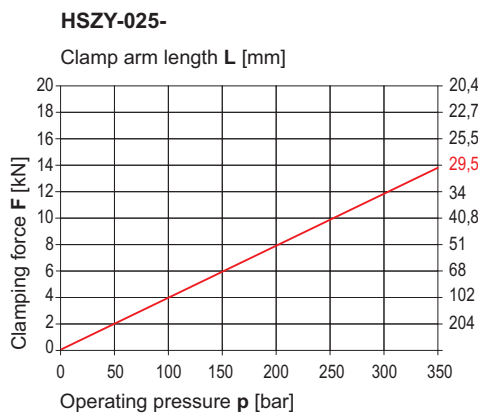
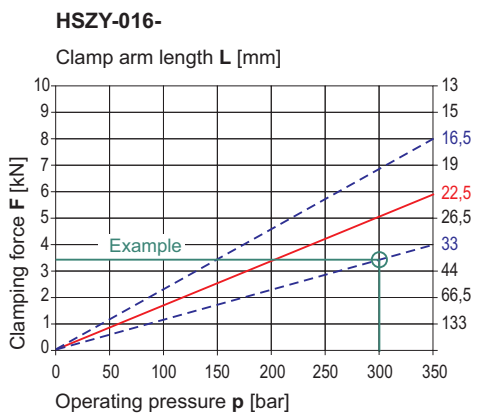

--- Clamp arm (standard)
— Drawing example

Example:

values from diagram
max. operating pressure $p_{max.} = 350$ bar
 $F_{max.}$ at $p_{max.} = 4$ kN
clamp arm length $L = 33$ mm
operating pressure $p = 300$ bar
resulting clamping force $F = 3,43$ kN

Calculation:

$$\text{Clamping force } F = F_{max.} \times \frac{p}{p_{max.}} = 4 \text{ kN} \times \frac{300 \text{ bar}}{350 \text{ bar}} = 3,43 \text{ kN}$$